

INSTALLATION RECOMMENDATIONS FOR TENDRAIN™ GEONETS AND GEOCOMPOSITES

HANDLING AND STORAGE

Drainage geonets and drainage geocomposites rolls shall be shipped to the jobsite in a manner not to damage the rolls. The rolls shall be stored away from dirt, mud, and excessive heat. Refer to ASTM D4873 (Standard Guide for Identification, Storage, and Handling of Geosynthetic Rolls and Samples) for more detailed handling and storage of geosynthetics.

PLACEMENT

1. After the geomembrane/ substratum has been installed/ constructed, tested and approved by the Engineer, the surface shall be clean and free of excess dirt and debris.
2. The Contractor and the Installer shall handle all geonet/geocomposite materials in such a manner as to ensure it is not damaged in any way. Precautions shall also been taken to prevent damage to underlying layers during placement of the geonet/geocomposite.
3. The geonet/geocomposite roll should be installed down the slope, and precautions taken to minimize wrinkles. The tri-planar geocomposite directs flow predominately in the machine direction (along the roll length) and thus should be installed in the intended direction of flow. This is generally directly down slope unless the Engineer specifies an alternative drainage path.
4. In the presence of wind, all geonet/geocomposite materials shall be weighted with sandbags or the equivalent. Such sandbags shall be installed during placement and shall remain until replaced with specified overlying material.
5. If there are any obstructions (such as outlet pipes or monitoring wells) while deploying the geonet/geocomposite, the geonet/geocomposite shall be cut to fit around the obstruction. Care should be taken as to make sure there is no gap between the obstruction and the geocomposite, to prevent any soil particles from migrating into the geonet core.

SEAMS AND OVERLAPS

The geonet and each component of the geocomposite (geonet & geotextile(s)) will be secured or seamed to the like component at overlaps.

Geonet:

- Adjacent edges of the geonet along the roll length of the geonet/geocomposite, should be overlapped 2-3 inches, see Figure 1 (a), or if approved by the Engineer based on the site specific conditions, placed with the edges of each geonet butted against each other, see Figure 1(b). These overlaps shall be joined by tying the geonet cores together with white or yellow plastic fasteners (minimum tensile strength of 100 lbs). These ties shall be spaced at a maximum of every 5 feet along the roll length.

Continued on back...

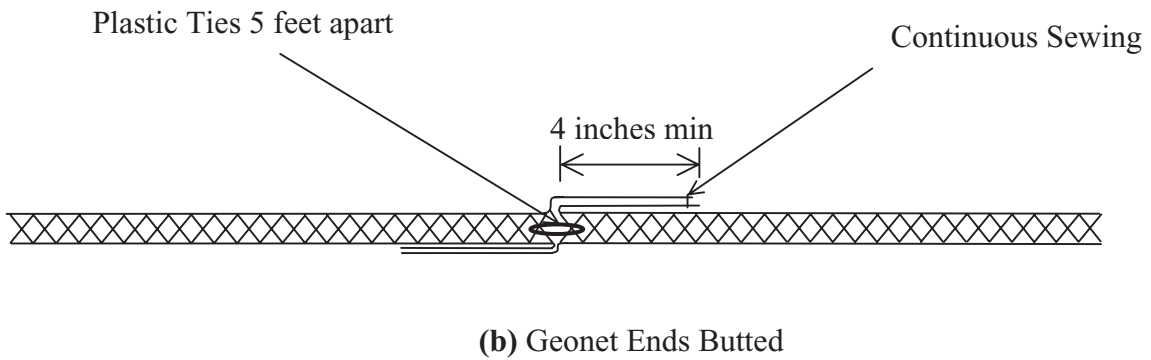
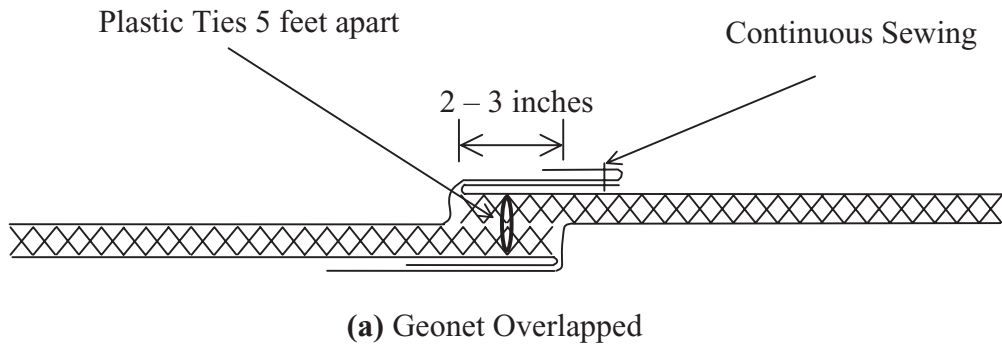

Figure 1 Overlap Along Roll Length

- Adjoining geonet/geocomposite rolls (end to end) along the roll width should have the geonet overlapped a minimum of 12 inches across the roll width, see Figure 2. Geonet should be tied every 12 inches across the roll width or as specified by the Engineer.

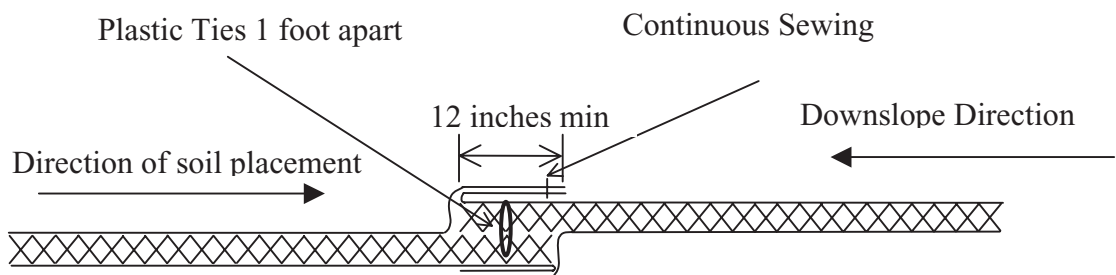

Figure 2 Overlap Along Roll Width (CD)

Continued on next page...

Geotextile:

- The bottom layer of geotextile (if any) shall be overlapped, unless the Engineer specifies differently.
- The top layers of geotextiles shall be sewn together, or at the discretion of the Engineer may be heat bonded or wedge weld. Geotextiles shall be overlapped a minimum of 1 inch prior to seaming or heat bonding, if heat bonding is to be used, care must be taken to avoid burn through of the geotextile. It is important that the geotextiles be joined continuously to the adjacent and adjoining rolls as to prevent any fugitive particle migration into the geonet core flow channels.

Slope Corners:

- In the slope corners, the direction of the slope changes at the corner diagonal line as illustrated in Figure 3. It's recommended to first place an additional panel along the corner diagonal line of the adjacent slope. The panels from the opposite slope should be placed to extend on top of the additional panel. Then the panel for the slope which contains the additional panel should be placed to meet (butted) the opposite slope panels.

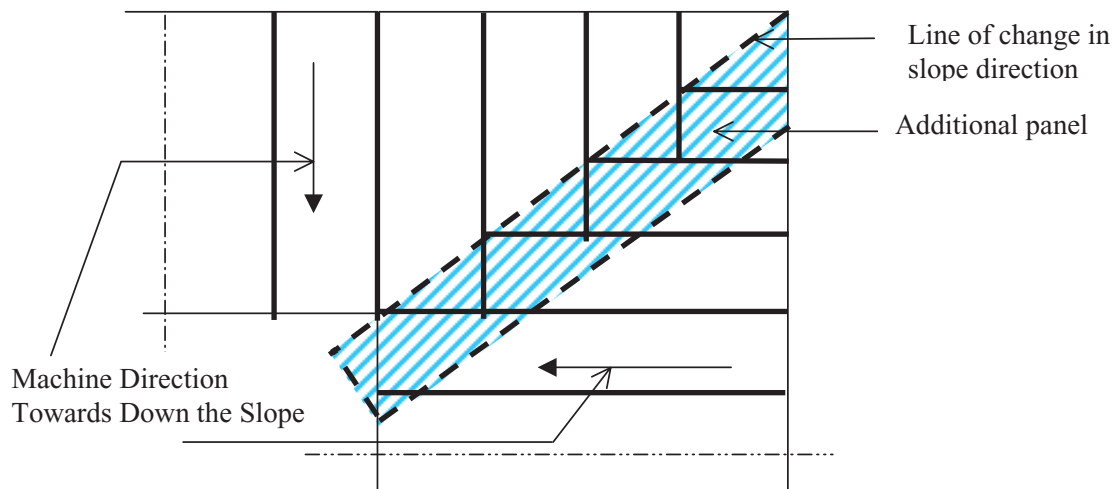

Figure 3 Details of Slope Corners

REPAIR

Prior to covering the deployed geocomposite, each roll shall be inspected for damage. Potential repair techniques will be addressed separately for just geotextile damage and for geonet damage on the geocomposite.

Geotextile damage:

Tenax recommends patching small holes with an 8" x 8" geotextile piece. Apply the spray adhesive (Note: 3M Hi-Strength 90 adhesive is the recommended adhesive.) to one side of the 8x8" textile patch. Center and apply the 8x8" textile patch over the small holes in the geotextile. Firmly press 8x8" textile patch over repair area. If the damaged area of the geotextile is greater than this patch size, a bigger patch is recommended instead of using a multitude of 8" x 8" patches. If the geotextile is damaged beyond 50 percent of the width of the roll, a full width piece of geotextile shall be cap-stripped over the damaged area as recommended above and seamed to the adjacent panels.

Geonet damage:

Damage to the geonet portion of the deployed geocomposite shall be patched by placing a geonet or geocomposite patch extending 12 inches beyond the edges of the damaged area. The patch shall be secured to the original geonet by tying every 6 inches with approved tying devices. If the damage on the geonet portion of the deployed geocomposite is more than 50 percent of the width of the roll, this entire full width section shall be cut out, and the two portions of the geonet (end to end) shall be joined as explained above.

Continued on back...

COVER SOIL PLACEMENT

1. Placement of the cover soil shall proceed immediately following the placement of the geocomposite and its consequent approval by the responsible party. All "70% retained strength after 500 hrs UV exposure" geotextiles shall be covered within 14 days; all UV "95% retained strength after 500 hrs UV exposure" geotextiles shall be covered within 40 days.
2. Any cover material shall be placed to assure that the geocomposite is not damaged. No construction equipment shall operate directly on the geocomposite. The use of lightweight machinery (i.e. general low ground pressure machines such as ATV's to facilitate deployment is allowed). The specified fill material shall be placed at a minimum of 12 inches thick above the geocomposite to prevent damage, and spread utilizing wide track equipment. The cover soil shall be placed on the geocomposite from the bottom of the slope proceeding upwards and in a manner which prevents instability of the cover soil, minimize wrinkles, or damage to the geocomposite.

